

Hendrick

ARCHITECTURAL

Fountain Covers & Trench Drains Technical Sheet

877-840-0881





www.hendrickarch.com

arch@hendrickcorp.com

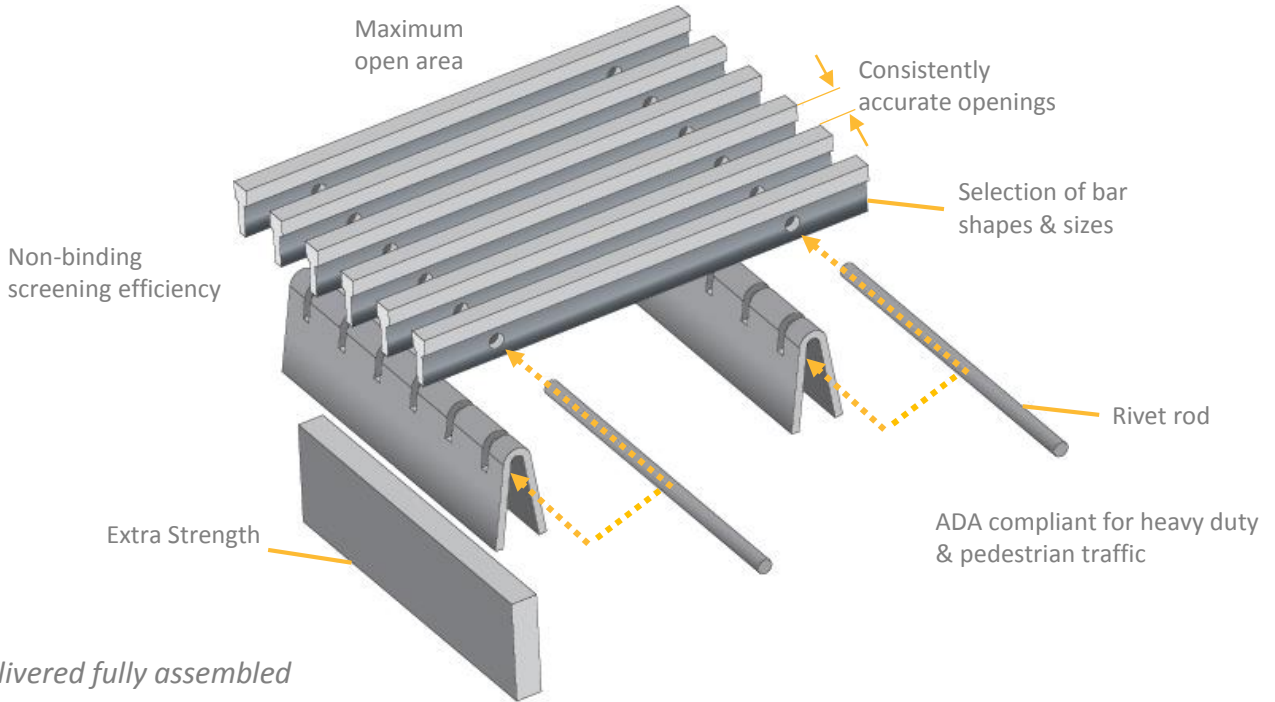
Carbondale, PA | Elgin, IL | Owensboro, KY

Hendrick's *Profile Bar** is manufactured using a mechanically interlocked proprietary method of construction, making it one of the strongest systems available on the market. It's perfect for applications that require high strength or a very flat surface.



| Profile Bar Images not to scale |  |  |  |  |
|------------------------------------|---|---|---|---|
| | T16 | B16 | B12 | B9 |
| Bar Width | .250" | .250" | .187" | .140" |
| Assembly Depths | 1-1/4" | 11/16" 13/16" 1-1/8" | 11/16" 13/16" 1-1/8" | 5/8" 3/4" 1-1/8" |
| <u>Options</u> | | | | |
| Anti-Slip Coating | ✓ | ✓ | ✓ | ✓ |

 *Hendrick's proprietary high-strength, mechanically interlocked construction method.

Hendrick

ARCHITECTURAL

Fountain Covers & Trench Drains Load Chart

877-840-0881

www.hendrickarch.com

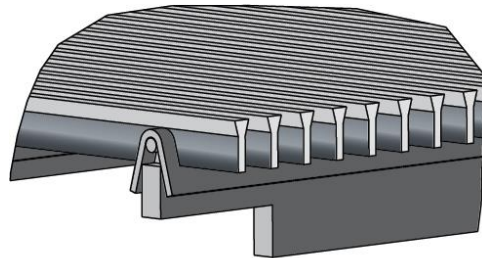
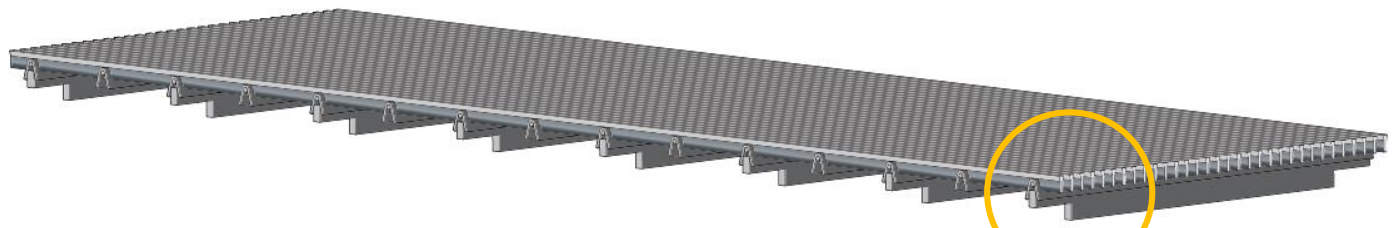
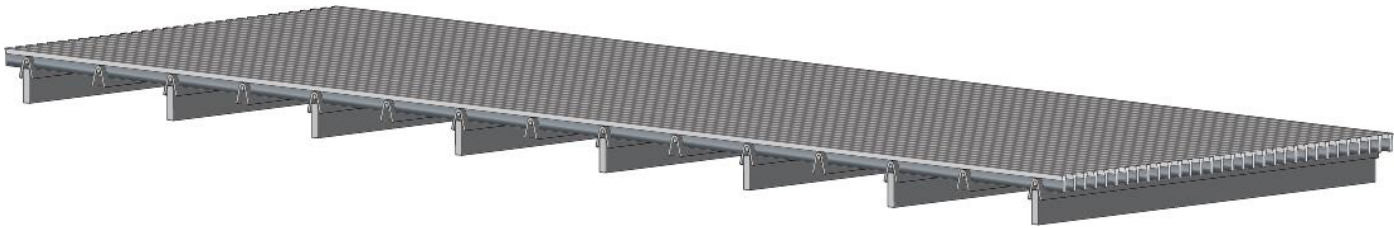

arch@hendrickcorp.com

Carbondale, PA | Elgin, IL | Owensboro, KY



Inserts – Optional Notched

Load Recommendation Guide

| | |
|---|--|
|  | <p>Pedestrian</p> <ul style="list-style-type: none"> • Loads of 1-300 PSF • Recommended for pedestrians, bicycles and wheel chair traffic |
|  | <p>Auto</p> <ul style="list-style-type: none"> • Loads up to 2,200 lbs. • Recommended for medium-duty pneumatic tire traffic, autos and light trucks at speeds less than 20 mph |
|  | <p>H-20</p> <ul style="list-style-type: none"> • Loads up to 20,800 lbs. • Recommended for heavy-duty pneumatic tire forklifts and tractor trailers at speeds less than 20 mph |

Hendrick

ARCHITECTURAL

Fountain Covers & Trench Drains Load Chart





















877-840-0881

www.hendrickarch.com

arch@hendrickcorp.com

Carbondale, PA | Elgin, IL | Owensboro, KY

Chart based on minimum depth of 1-1/8" for open span listed below.

| | BAR | Insert Size (in) | Insert Spacing (in) | Support Spacing (in) | BAR | Insert Size (in) | Insert Spacing (in) | Support Spacing (in) | BAR | Insert Size (in) | Insert Spacing (in) | Support Spacing (in) |
|--|-----|------------------|---------------------|----------------------|-----|------------------|---------------------|----------------------|-----|------------------|---------------------|----------------------|
| 6" Grate | | | | | | | | | | | | |
|  | B9 | - | - | 3 | B12 | - | - | 3 | T16 | - | - | 3 |
|  | B9 | 1/4 x 1 | 3 | 3 | B12 | 1/4 x 1 | 3 | 3 | T16 | 1/4 x 1 | 3 | 3 |
|  | B9 | 1/4 x 1-1/4 | 3 | 3 | B12 | 1/4 x 1-1/4 | 3 | 3 | T16 | 1/4 x 1-1/4 | 3 | 3 |
| 10" Grate | | | | | | | | | | | | |
|  | B9 | 1/4 x 1/2 | 6 | 3 | B12 | 1/4 x 1/2 | 6 | 3 | T16 | 1/4 x 1/2 | 6 | 3 |
|  | B9 | 1/4 x 1-1/2 | 6 | 3 | B12 | 1/4 x 1-1/2 | 6 | 3 | T16 | 1/4 x 1-1/2 | 6 | 3 |
|  | B9 | 1/4 x 1-1/2 | 3 | 3 | B12 | 1/4 x 1-1/2 | 3 | 3 | T16 | 1/4 x 2 | 3 | 3 |
| 14" Grate | | | | | | | | | | | | |
|  | B9 | 1/4 x 1 | 6 | 3 | B12 | 1/4 x 1 | 6 | 3 | T16 | 1/4 x 1 | 6 | 3 |
|  | B9 | 1/4 x 1-1/2 | 3 | 3 | B12 | 1/4 x 1-1/2 | 3 | 3 | T16 | 1/4 x 2 | 6 | 3 |
|  | B9 | 1/4 x 2-1/2 | 3 | 3 | B12 | 1/4 x 2-1/2 | 3 | 3 | T16 | 1/4 x 2-1/2 | 3 | 3 |
| 20" Grate | | | | | | | | | | | | |
|  | B9 | 1/4 x 1 | 6 | 3 | B12 | 1/4 x 1 | 3 | 3 | T16 | 1/4 x 1 | 3 | 3 |
|  | B9 | 1/4 x 2 | 3 | 3 | B12 | 1/4 x 2 | 3 | 3 | T16 | 1/4 x 2 | 3 | 3 |
|  | B9 | 1/4 x 3-1/2 | 3 | 3 | B12 | 1/4 x 3-1/2 | 3 | 3 | T16 | 1/4 x 3-1/2 | 3 | 3 |
| 26" Grate | | | | | | | | | | | | |
|  | B9 | 1/4 x 1 -1/2 | 3 | 3 | B12 | 1/4 x 1 -1/2 | 3 | 3 | T16 | 1/4 x 1 -1/2 | 3 | 3 |
|  | B9 | 1/4 x 2-1/2 | 3 | 3 | B12 | 1/4 x 2-1/2 | 3 | 3 | T16 | 1/4 x 2-1/2 | 3 | 3 |
|  | B9 | 1/4 x 4 | 3 | 3 | B12 | 1/4 x 4 | 3 | 3 | T16 | 1/4 x 4 | 3 | 3 |
| 36" Grate | | | | | | | | | | | | |
|  | B9 | 1/4 x 2 | 6 | 3 | B12 | 1/4 x 2 | 6 | 3 | T16 | 1/4 x 2 | 6 | 3 |
|  | B9 | 1/4 x 3 | 3 | 3 | B12 | 1/4 x 3 | 3 | 3 | T16 | 1/4 x 3 | 3 | 3 |
|  | B9 | 1/4 x 5-1/2 | 3 | 3 | B12 | 1/4 x 5-1/2 | 3 | 3 | T16 | 1/4 x 5-1/2 | 3 | 3 |
| 48" Grate | | | | | | | | | | | | |
|  | B9 | 1/4 x 2-1/2 | 6 | 3 | B12 | 1/4 x 2-1/2 | 6 | 3 | T16 | 1/4 x 2-1/2 | 6 | 3 |
|  | B9 | 1/4 x 3-1/2 | 3 | 3 | B12 | 1/4 x 3-1/2 | 3 | 3 | T16 | 1/4 x 3-1/2 | 3 | 3 |
|  | B9 | 1/4 x 6-1/2 | 3 | 3 | B12 | 1/4 x 6-1/2 | 3 | 3 | T16 | 1/4 x 6-1/2 | 3 | 3 |