

TYP PANEL FASTENING DETAIL

PROVIDE NEOPRENE SPACER OR ISOLATION TAPE WHERE ALL ALUMINUM FRAMING COMES IN CONTACT WITH CONCRETE OR STEEL CONSTRUCTION

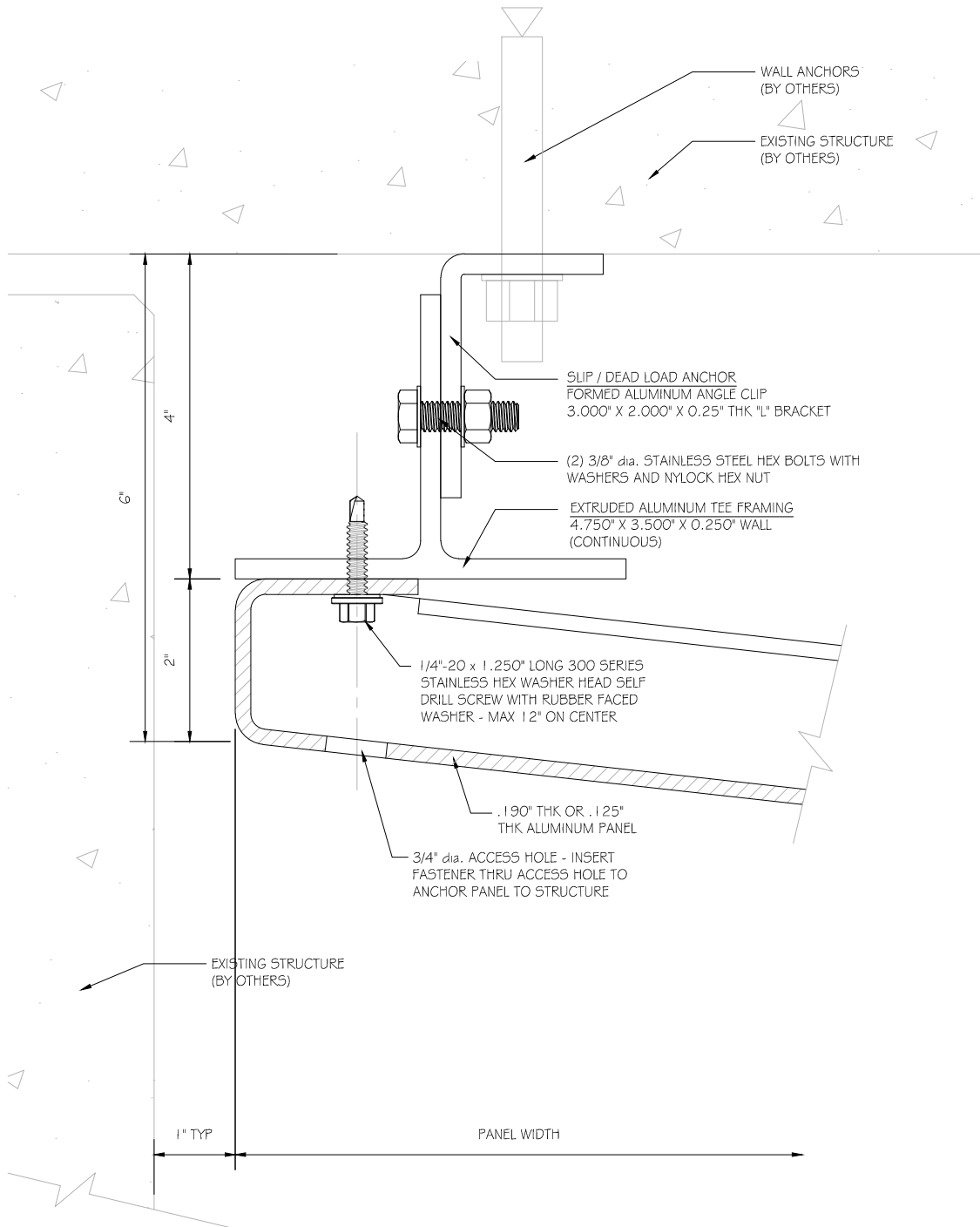

1 END WALL DETAIL

PROVIDE NEOPRENE SPACER OR ISOLATION TAPE WHERE ALL ALUMINUM FRAMING COMES IN CONTACT WITH CONCRETE OR STEEL CONSTRUCTION

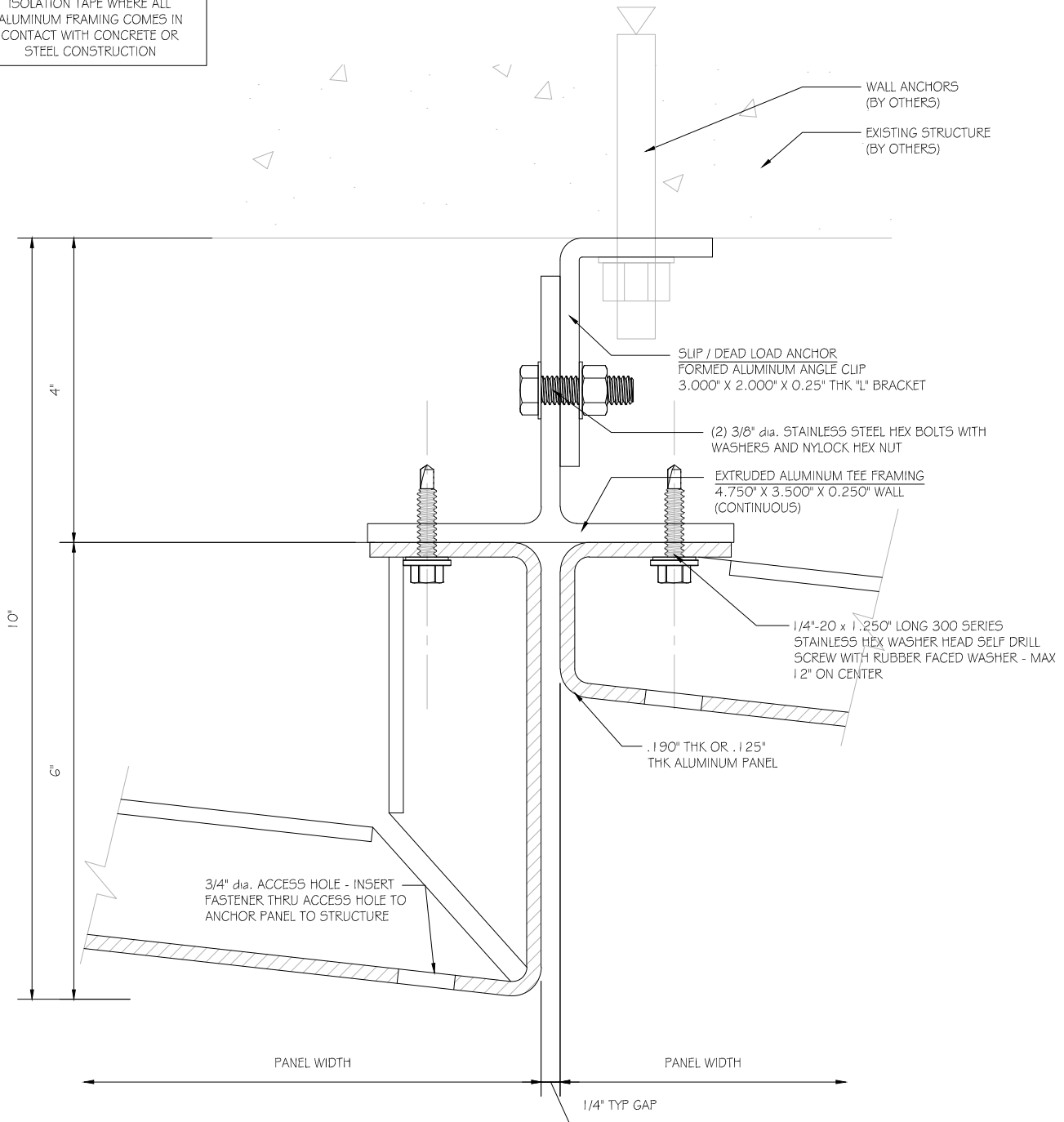

PROVIDE NEOPRENE SPACER OR ISOLATION TAPE WHERE ALL ALUMINUM FRAMING COMES IN CONTACT WITH CONCRETE OR STEEL CONSTRUCTION

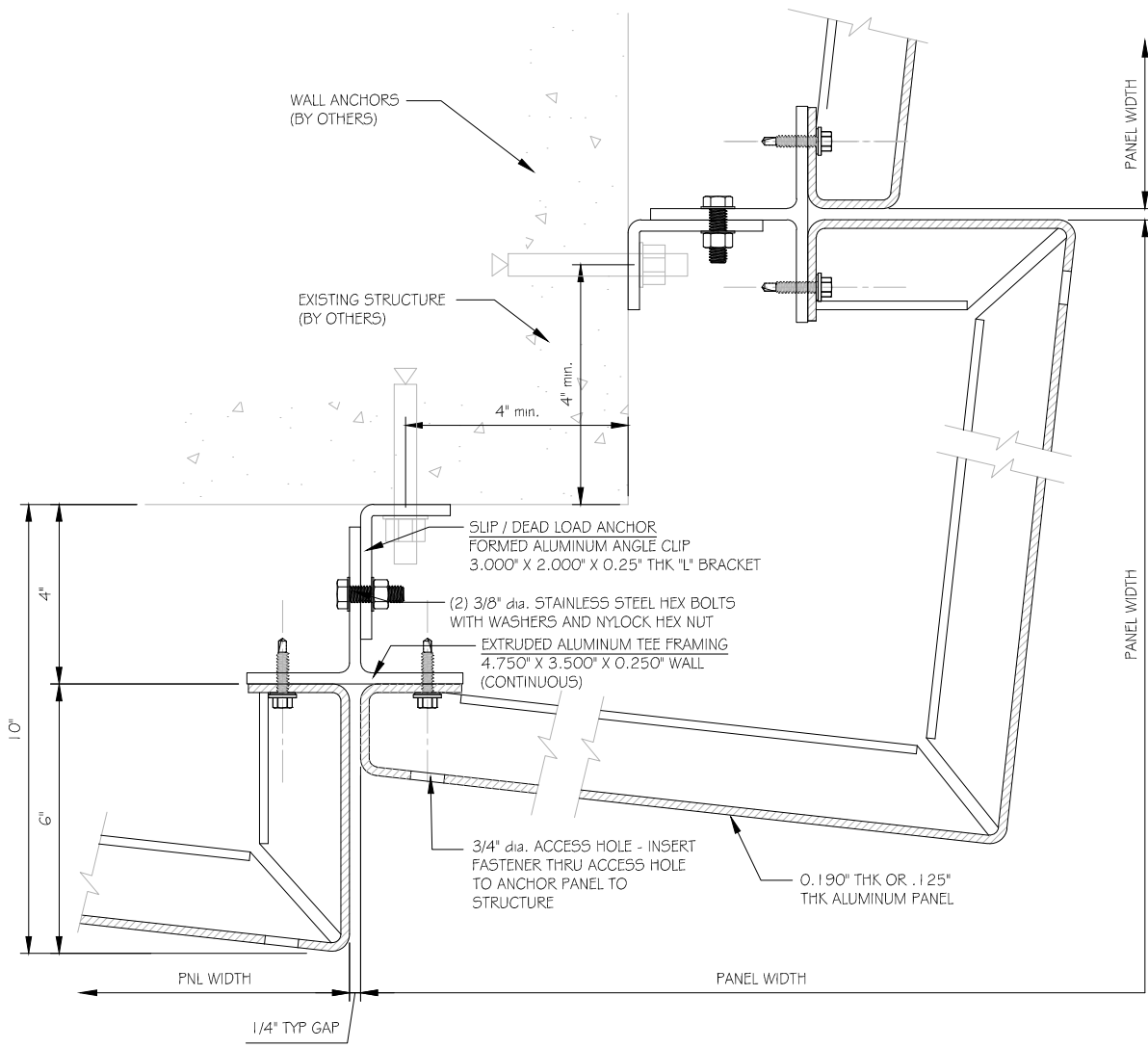

3 OUTSIDE CORNER

PROVIDE NEOPRENE SPACER OR ISOLATION TAPE WHERE ALL ALUMINUM FRAMING COMES IN CONTACT WITH CONCRETE OR STEEL CONSTRUCTION

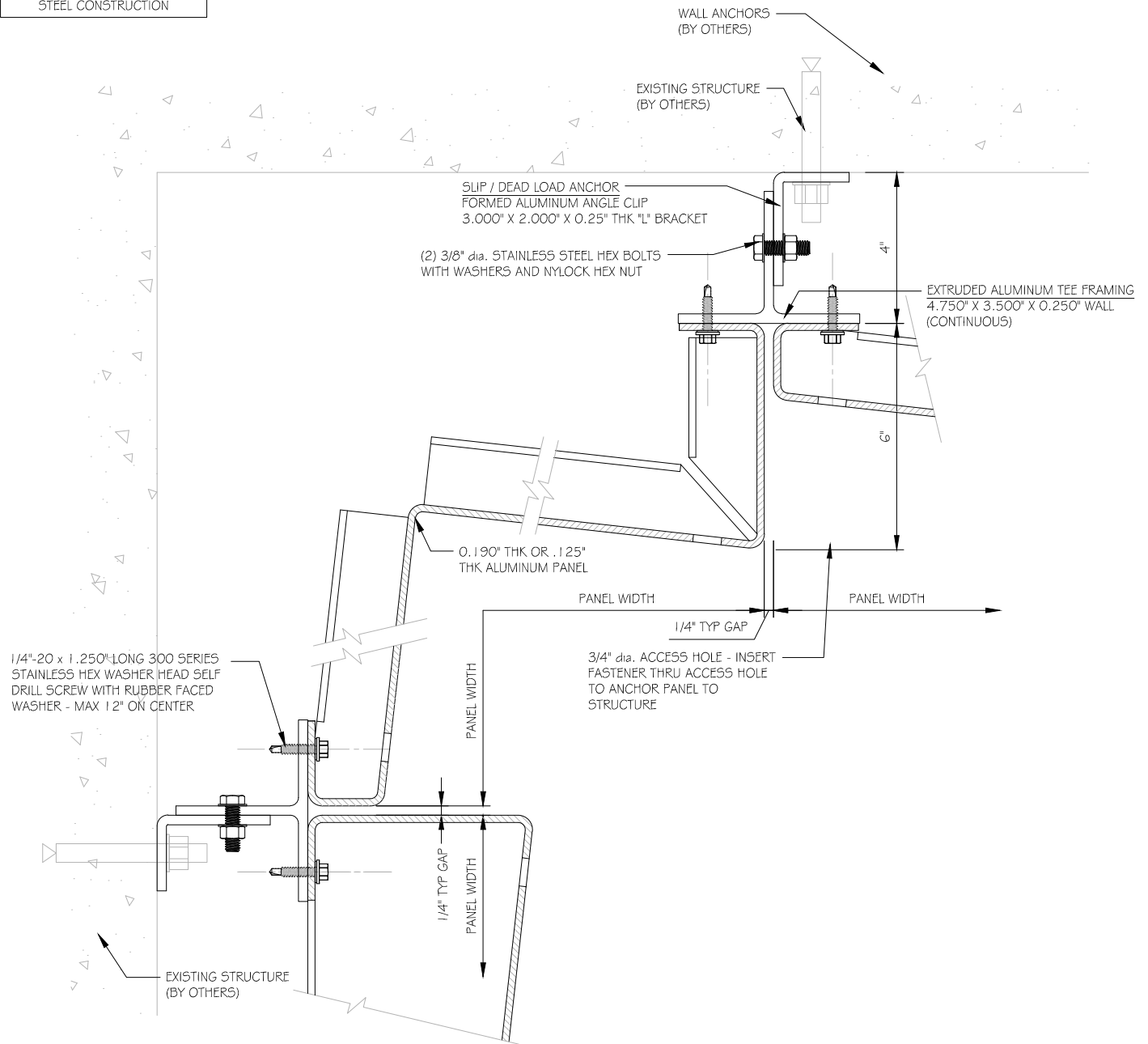

PROVIDE NEOPRENE SPACER OR ISOLATION TAPE WHERE ALL ALUMINUM FRAMING COMES IN CONTACT WITH CONCRETE OR STEEL CONSTRUCTION

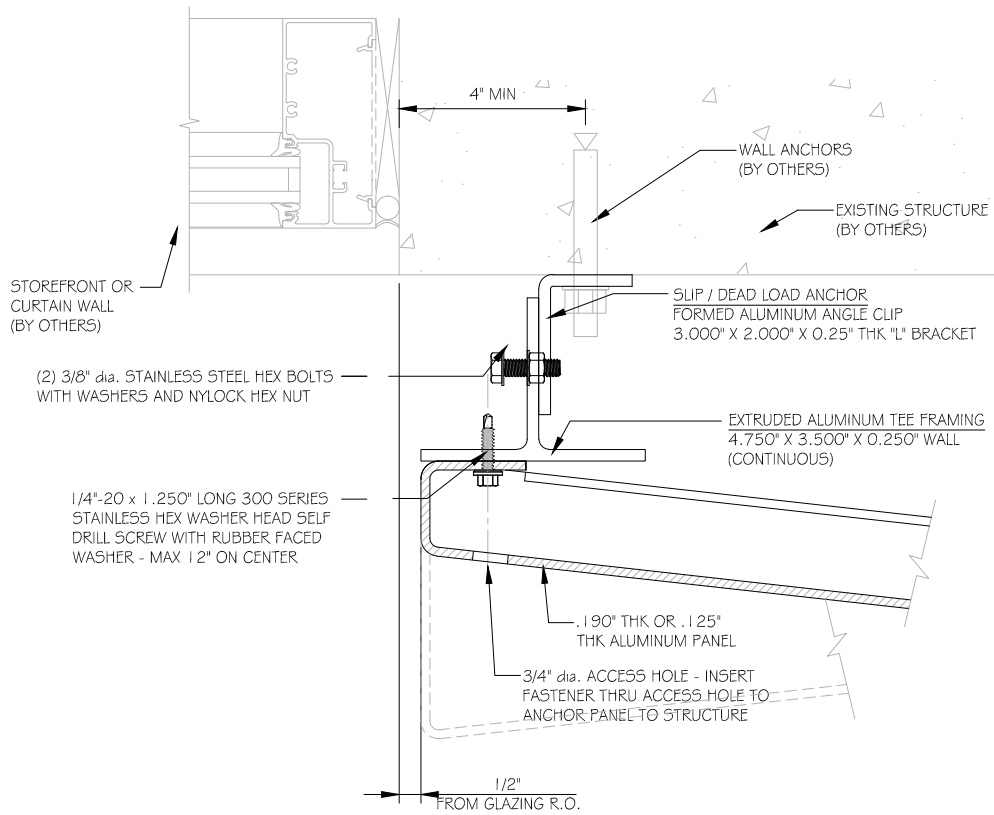

5 WINDOW JAMB

PROVIDE NEOPRENE SPACER OR ISOLATION TAPE WHERE ALL ALUMINUM FRAMING COMES IN CONTACT WITH CONCRETE OR STEEL CONSTRUCTION

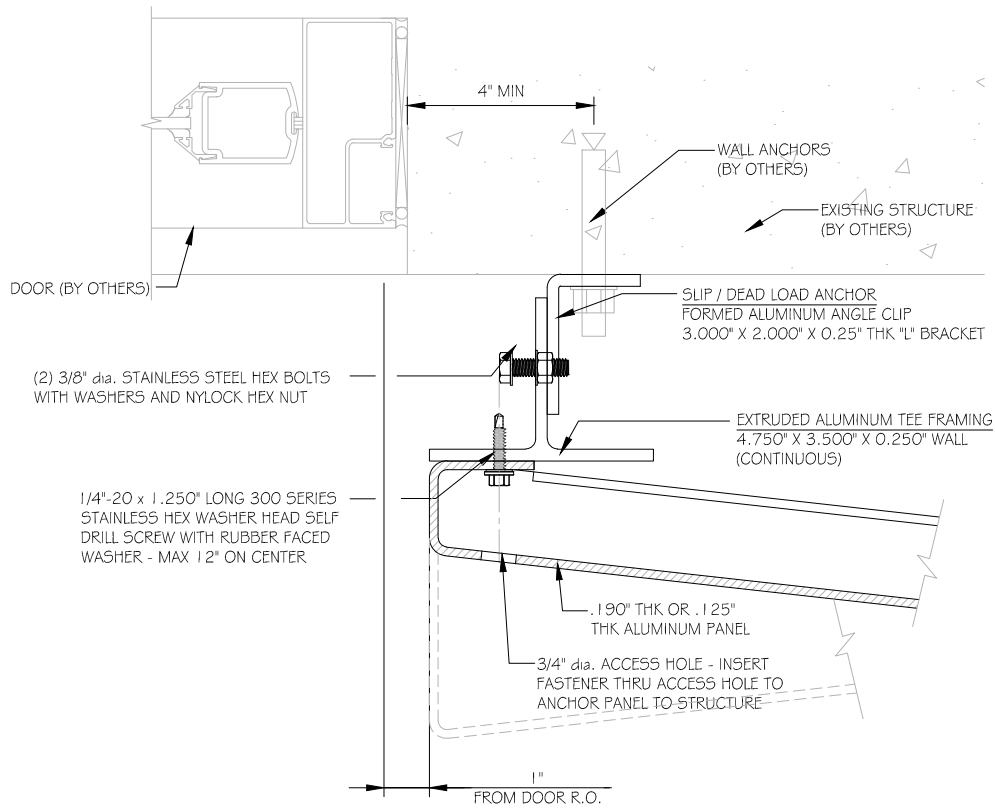

6 DOOR JAMB

PROVIDE NEOPRENE SPACER OR ISOLATION TAPE WHERE ALL ALUMINUM FRAMING COMES IN CONTACT WITH CONCRETE OR STEEL CONSTRUCTION

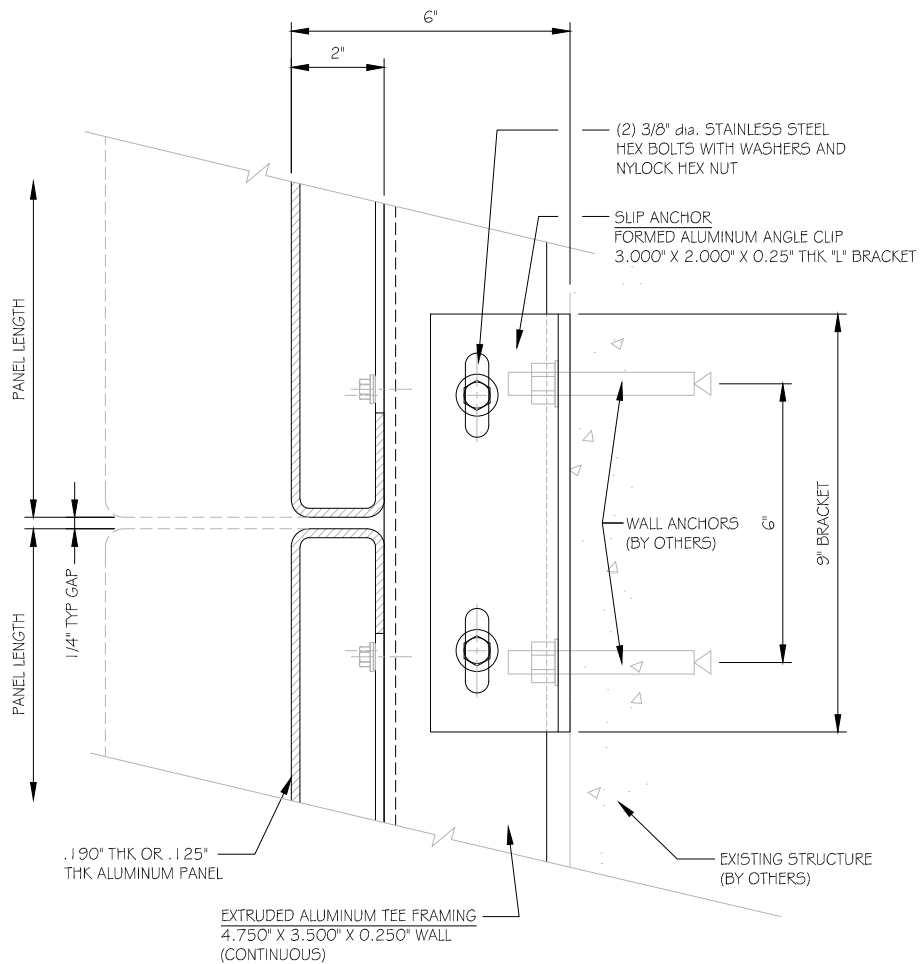

7 HORIZONTAL JOINT SLIP CONNECTION

PROVIDE NEOPRENE SPACER OR ISOLATION TAPE WHERE ALL ALUMINUM FRAMING COMES IN CONTACT WITH CONCRETE OR STEEL CONSTRUCTION

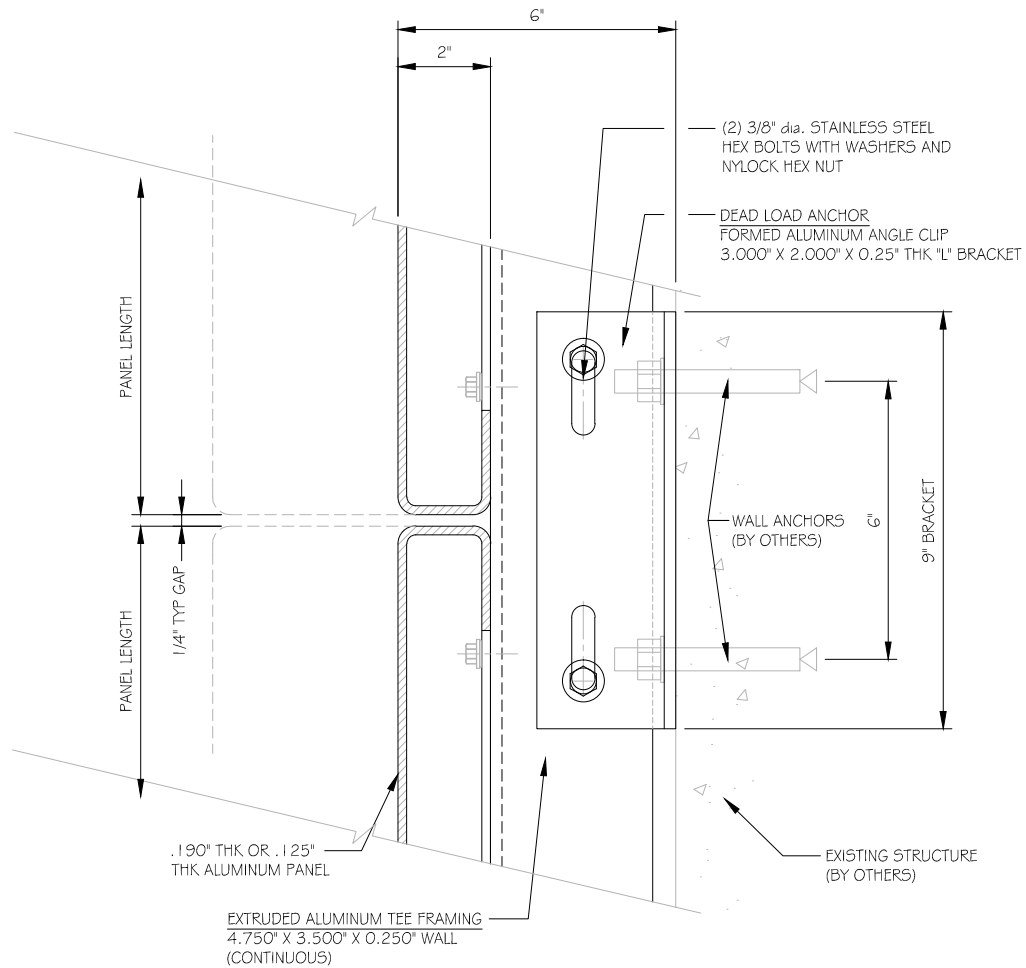

8 HORIZONTAL JOINT
DEAD LOAD CONNECTION

PROVIDE NEOPRENE SPACER OR ISOLATION TAPE WHERE ALL ALUMINUM FRAMING COMES IN CONTACT WITH CONCRETE OR STEEL CONSTRUCTION

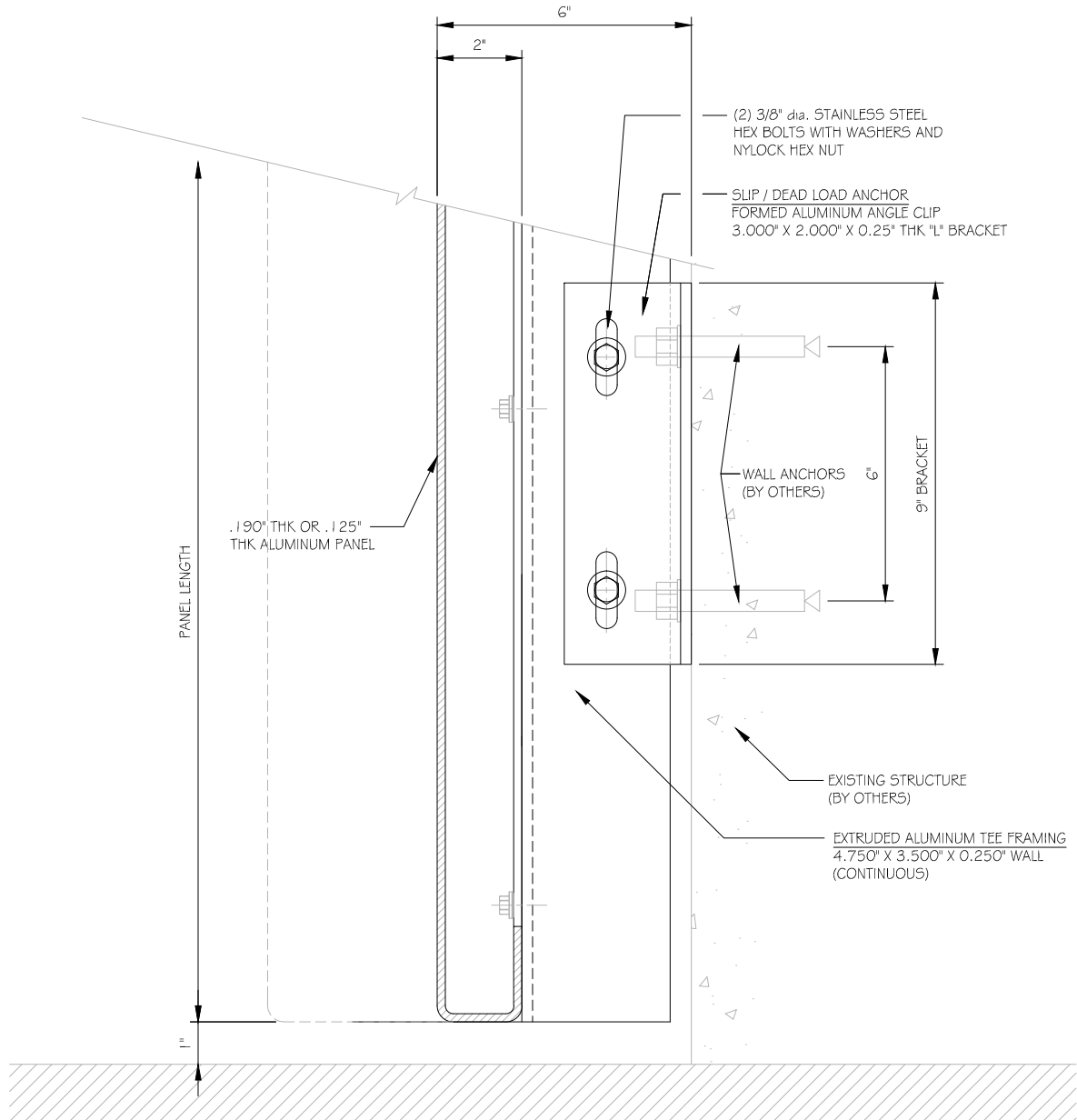

9 BOTTOM CONDITION

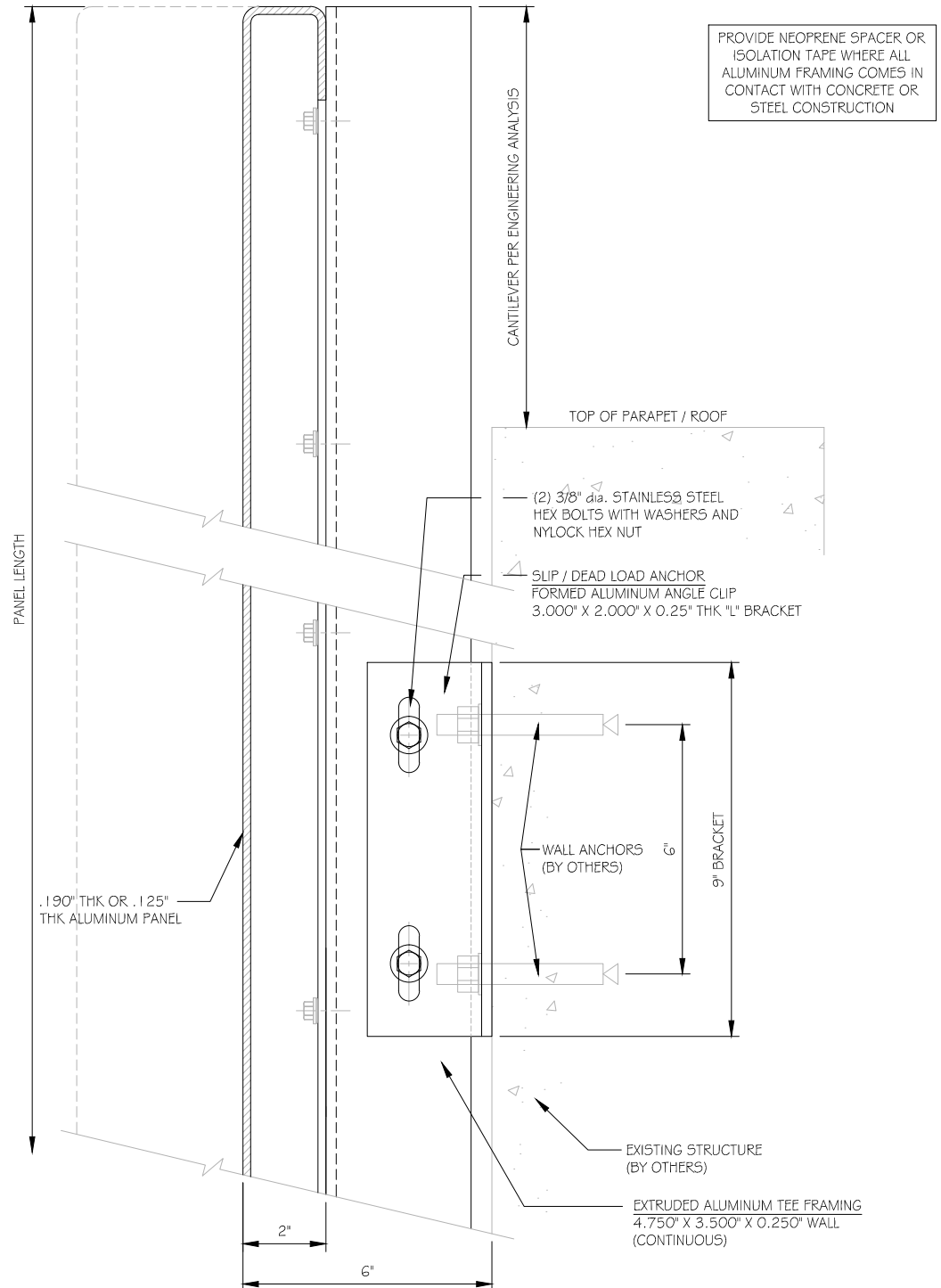

PROVIDE NEOPRENE SPACER OR ISOLATION TAPE WHERE ALL ALUMINUM FRAMING COMES IN CONTACT WITH CONCRETE OR STEEL CONSTRUCTION

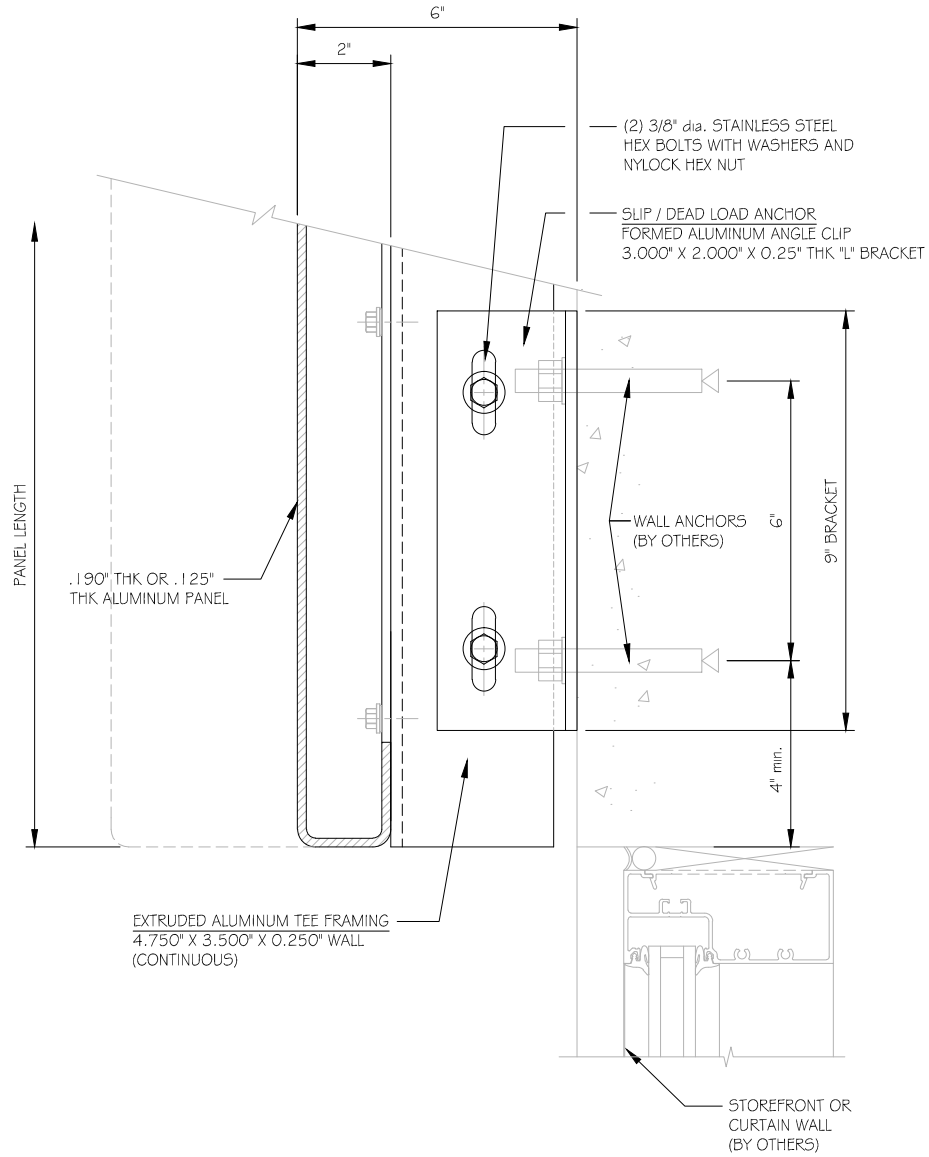

PROVIDE NEOPRENE SPACER OR ISOLATION TAPE WHERE ALL ALUMINUM FRAMING COMES IN CONTACT WITH CONCRETE OR STEEL CONSTRUCTION

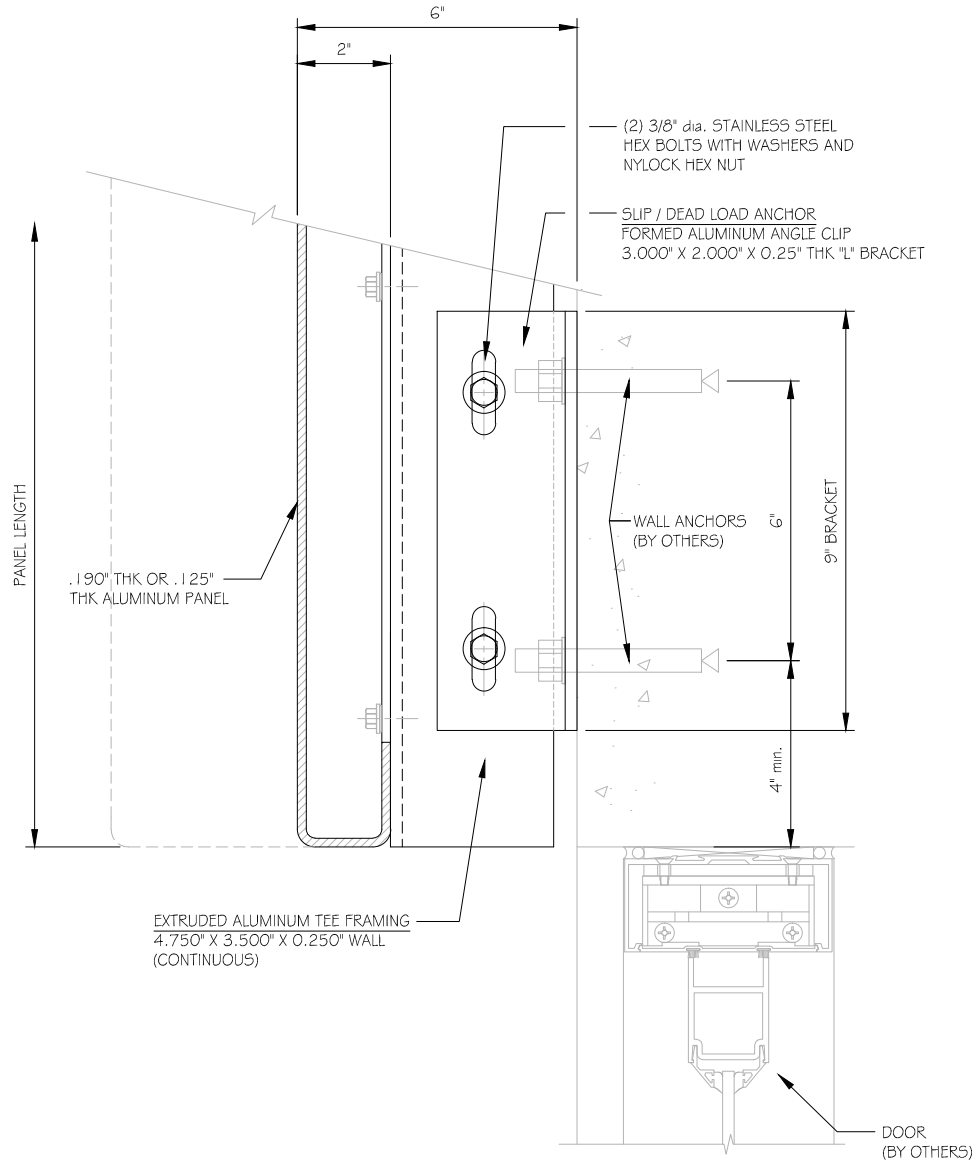

PROVIDE NEOPRENE SPACER OR ISOLATION TAPE WHERE ALL ALUMINUM FRAMING COMES IN CONTACT WITH CONCRETE OR STEEL CONSTRUCTION

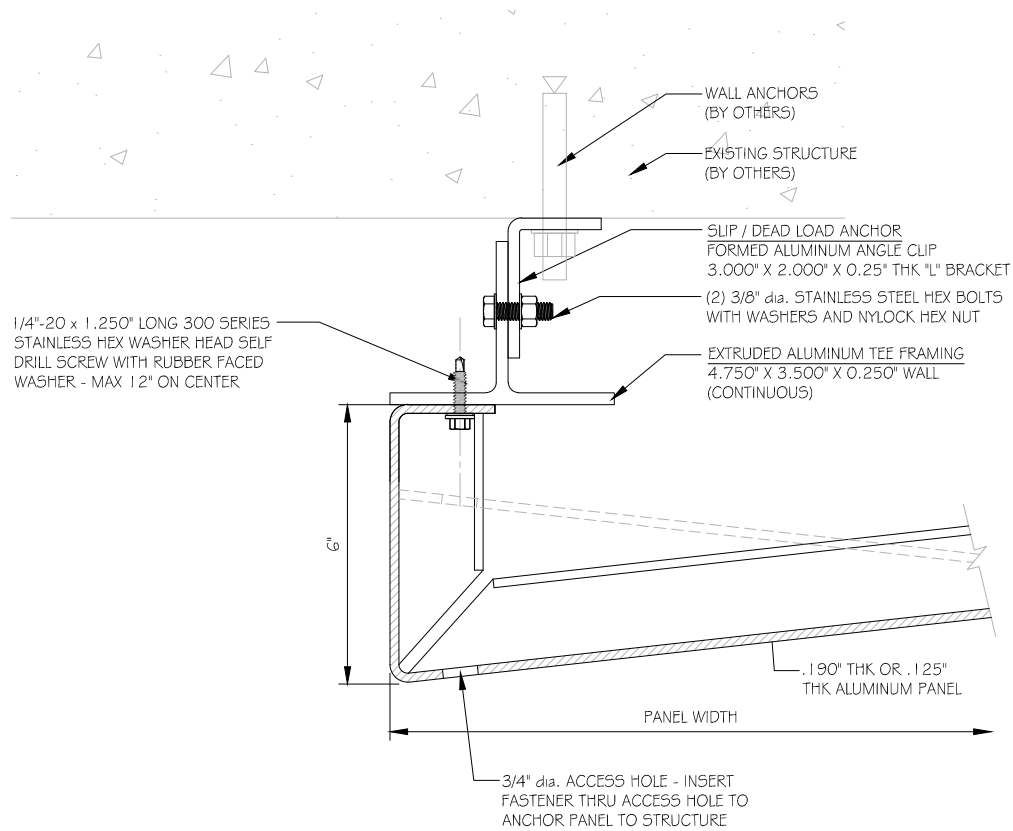

PROVIDE NEOPRENE SPACER OR ISOLATION TAPE WHERE ALL ALUMINUM FRAMING COMES IN CONTACT WITH CONCRETE OR STEEL CONSTRUCTION

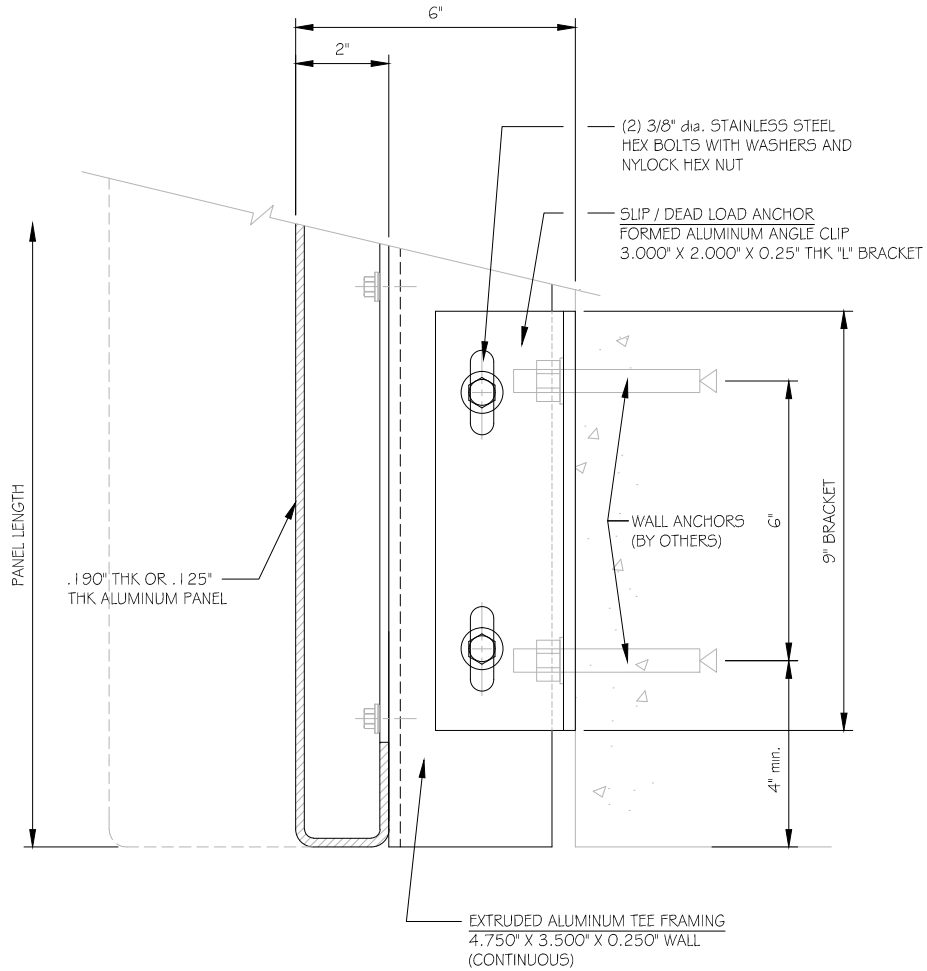

PROVIDE NEOPRENE SPACER OR ISOLATION TAPE WHERE ALL ALUMINUM FRAMING COMES IN CONTACT WITH CONCRETE OR STEEL CONSTRUCTION

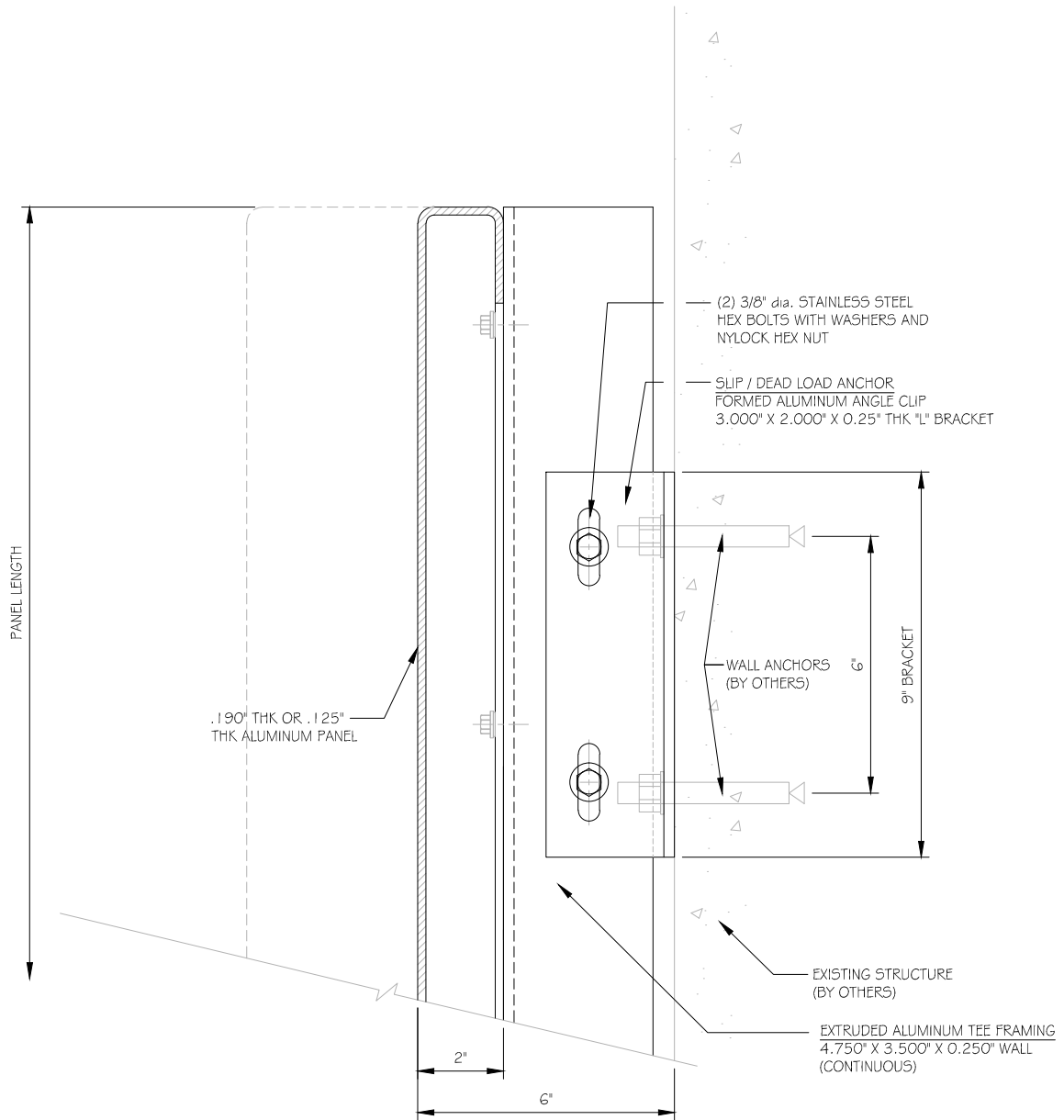

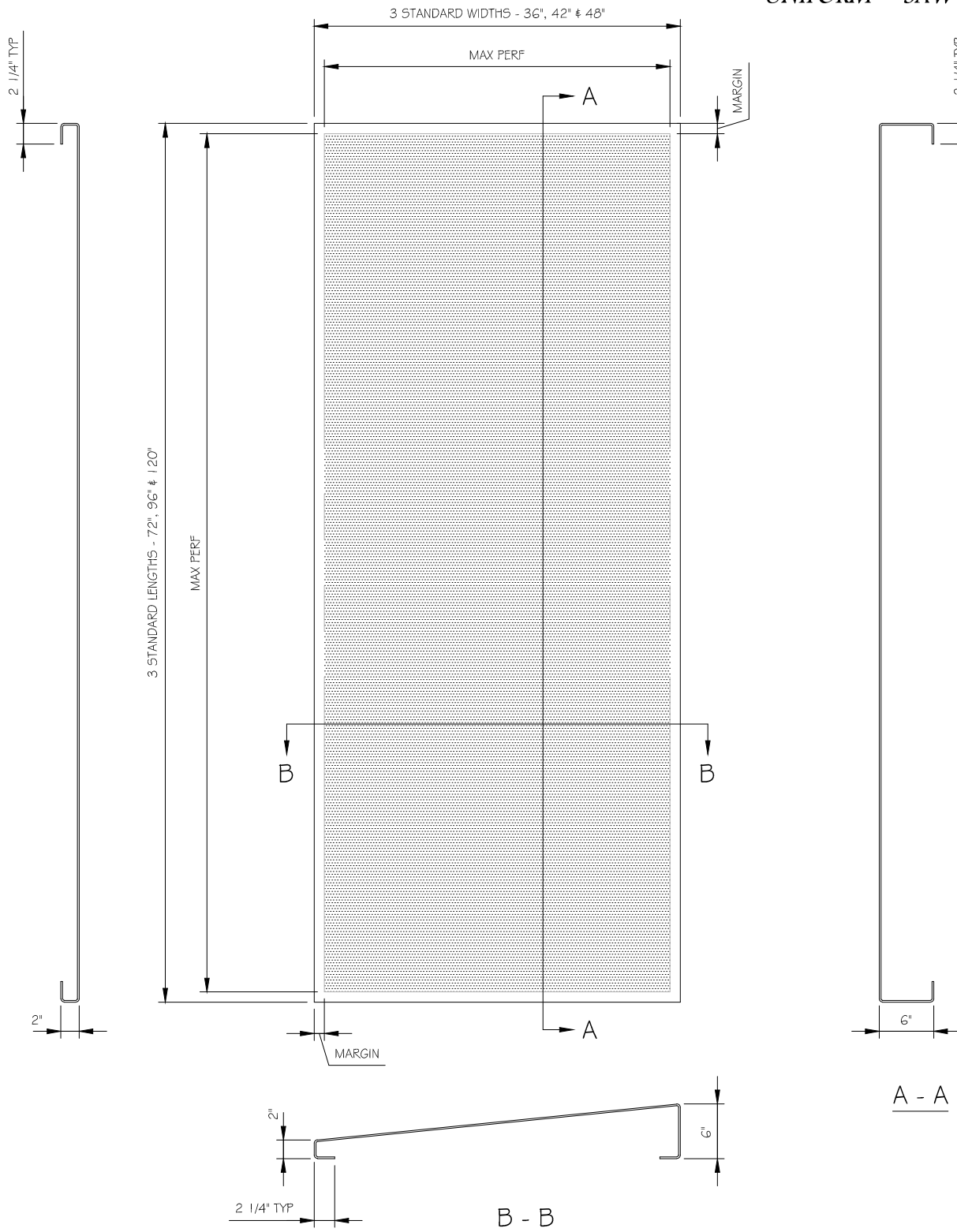

MARGIN = 1.125" (0.190" THK AL) MARGIN = 0.750" (0.125" THK AL)

1/8" (.125") THICK 5052-H32 ALUMINUM

PANEL WIDTH BY PERF PATTERN & WIND LOAD PRESSURE					
PERF PATTERN INFO			MAX PANEL WIDTH		
PERF DIAMETER (IN)	CENTER SPACING (IN)	% OPEN AREA	30 PSF	50 PSF	70 PSF
0.250	0.500	22.7	48	36	-
0.375	0.625	32.6	42	36	-
0.375	0.750	22.7	48	36	-
0.500	0.750	40.3	42	-	-
0.500	1.000	22.7	48	36	-
0.750	1.000	51.0	36	-	-
0.750	1.250	32.6	42	36	-
1.000	1.250	58.0	36	-	-
1.000	2.000	22.7	48	36	-
1.500	1.750	66.6	-	-	-
2.000	2.250	71.7	-	-	-
3.000	3.250	77.3	-	-	-

**NOTE: PANELS TO BE 36", 42" OR 48" WIDE.

3/16" (.190") THICK 5052-H32 ALUMINUM

PANEL WIDTH BY PERF PATTERN & WIND LOAD PRESSURE					
PERF PATTERN INFO			MAX. PANEL WIDTH		
PERF DIAMETER (IN)	CENTER SPACING (IN)	% OPEN AREA	30 PSF	50 PSF	70 PSF
0.250	0.500	22.7	48	48	48
0.375	0.625	32.6	48	48	48
0.375	0.750	22.7	48	48	48
0.500	0.750	40.3	48	48	42
0.500	1.000	22.7	48	48	48
0.750	1.000	51.0	48	42	36
0.750	1.250	32.6	48	48	48
1.000	1.250	58.0	48	42	36
1.000	2.000	22.7	48	48	48
1.500	1.750	66.6	48	42	36
2.000	2.250	71.7	48	42	36
3.000	3.250	77.3	48	42	36

**NOTE: PANELS TO BE 36", 42" OR 48" WIDE.

PANEL SYSTEM REQUIREMENTS & SPECIFICATIONS

- THIS TABLE IS INTENDED AS A GUIDE FOR THE ALLOWABLE LOADS FOR THE SPAN, HOWEVER ACTUAL CONDITIONS MUST BE REVIEWED BY A QUALIFIED PROFESSIONAL ENGINEER.
- PANELS TO BE MADE FROM 0.125" OR 0.190" THK AL 5052-H32
- PANELS TO BE ATTACHED ON THE LONG VERTICAL EDGES ONLY.
- PANEL FASTENERS TO BE SPACED AT MAXIMUM 12" ON CENTER.
- STANDARD PANEL WIDTHS TO BE 36", 42" & 48"
- STANDARD PANEL LENGTHS TO BE 72", 96" & 120"
- MAXIMUM DEFLECTION TO BE 1/60.
- PANEL WIND LOADING: 30 PSF, 50 PSF, 70 PSF
- CONSULT HENDRICK ARCHITECTURAL FOR FURTHER REVIEW OF N/A RESULTS.